



# e-JEST POSITIVE ENERGY OF THE CITY



in cooperation with



# e-JEST

# POSITIVE ENERGY NOW IN THE CITY

With features that push the boundaries of technology, e-JEST offers unique privileges and stimulates cities with positive energy. Are you ready for the future now?





**e-JEST**

## **ALSO KNOWN AS SMALL CITY BUS**

Designed to feed the main lines of city transportation, e-JEST can navigate narrow streets without difficulty thanks to its compact size. Therefore, it allows a transportation network that can expand and access every point in the city.



**135 kW**  
Max. Power



**290 Nm**  
Max. Torque



**25 %**  
Max. Gradeability



**70 km/h**  
Max. Speed

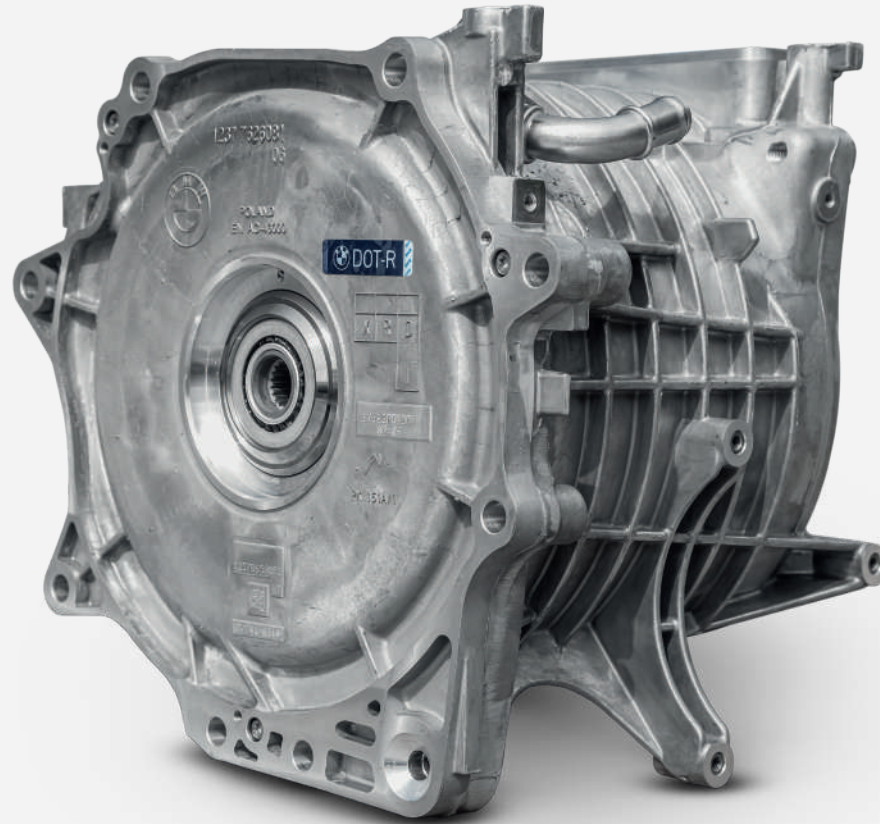

## Powerful BMW Electric Motor

Although e-JEST is battery powered, it is as powerful as diesel vehicles.

This power is derived from a BMW 100% electric motor which ensures strong acceleration performance. e-JEST is always ready with its strong, quiet and efficient motor to conquer any city terrain. e-JEST's efficient BMW motor generates high torque and reassures the driver in demanding situations.

Mechanic warranty is limited to 2 years or 200.000 km (whichever finishes first).

in cooperation with



## UNIQUE AND INNOVATIVE DESIGN

e-JEST respects and sustains the historical heritage of the city. Having a perfect look with its new age compact design, e-JEST is adapting to the texture of the city thanks to its small footprint.

It increases the image of the city and becomes an iconic figure.



## ATTRACTIVE DESIGN

### Charming Front Design

Traveling with e-JEST offers many privileges. Wide angle windshield and LED headlamps, grooved front grille and LED daytime running lamps create a stylish design detailed with sharp lines that leaves a lasting impression.





### Rear Design

Unique and award winning. e-JEST, which won a design award in Design Turkey, is created to bring a different atmosphere to the city in every aspect. e-JEST's view from the rear is so extraordinary that future designs will be influenced by it.

### Rims With An Aesthetic Appearance

It's in e-JEST's DNA to dominate eyes and feelings. The 16" aluminum alloy rims reflect its energetic soul with a flawless appearance on the road.

## Wide Angle View

With e-JEST, it is possible to look at life from a wide angle. The panoramic windshield designed to ensure a commanding view of the road, does not let anything escape from sight.

## LED Light Path

e-JEST exceeds your expectations with LED lighting that enhances visibility and safety, while giving an aesthetic appearance to the interior. For passengers, traveling with e-JEST is very pleasurable.





## JEST, ALREADY IN SERVICE

Jest has been meeting public transportation needs in many countries since 2013. Having proved itself with more than 7,700 units on the road, Jest continues to improve city life as being preferred every day in different locations of the world.



## EVERYTHING IS CONSIDERED FOR DRIVER'S COMFORT

Bringing a new dimension to cockpit; e-JEST makes driving more comfortable and convenient with its unique features including commanding seating position and broad visibility reducing driver fatigue.



Tiltable & Telescopic Electrohydraulic Leather Steering Wheel



8 Way Adjustable Pneumatic Driver Seat With Arm Rest



Driver Air Conditioner



Electric Heated Mirrors & Sidewalk Mirrors



Heated Windows and Windshield



Electric Roof Hatch

# POSITIVE FUTURE

## Zero Emission

e-JEST is green, not only in color but in design. e-JEST keeps future generations healthier with 0% emissions.



**POSITIVE LIFE**



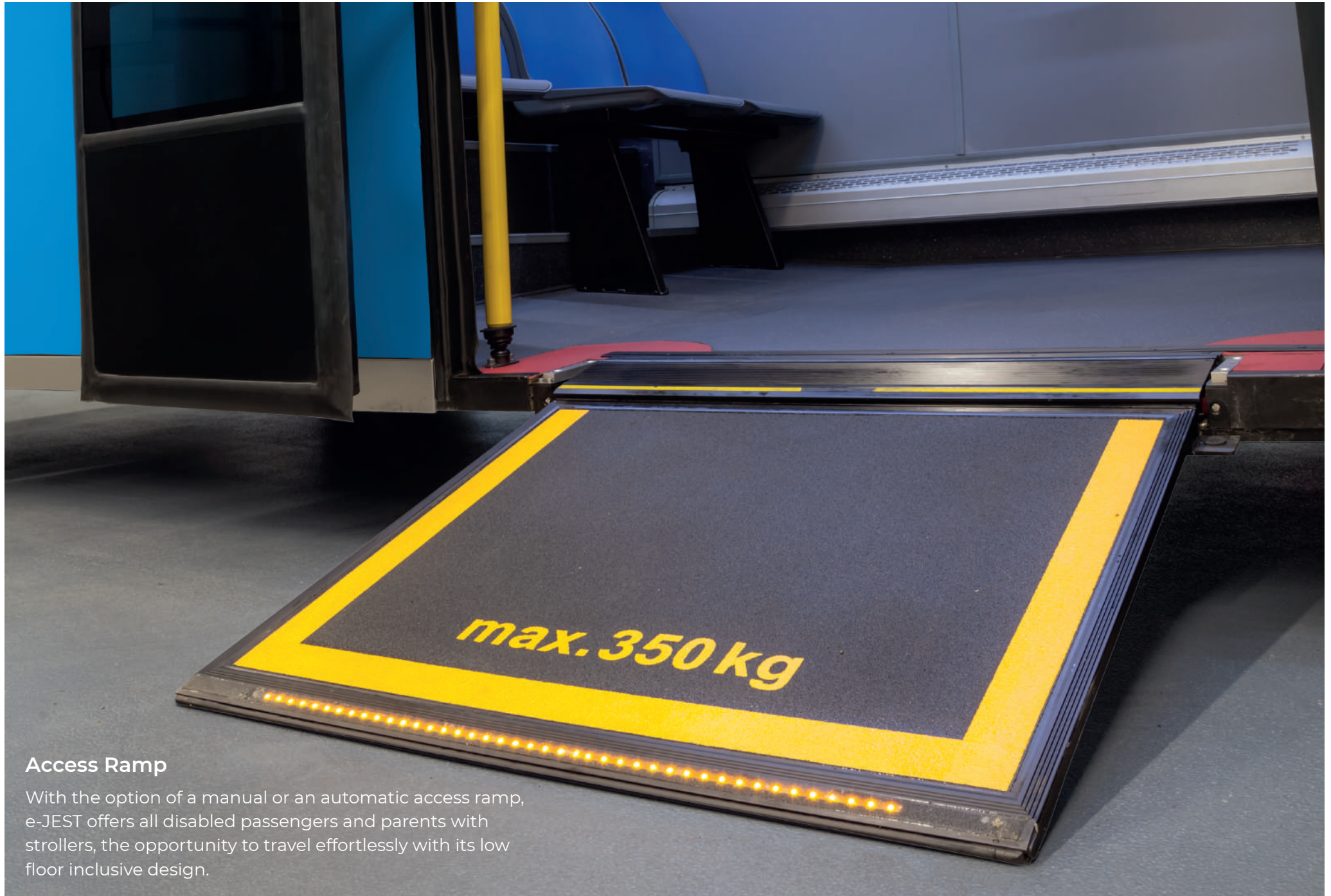

### Access Ramp

With the option of a manual or an automatic access ramp, e-JEST offers all disabled passengers and parents with strollers, the opportunity to travel effortlessly with its low floor inclusive design.

## Silent

With e-JEST, there is a different energy for every moment. Providing a quiet first class ride for its passengers and promising a more peaceful city life, e-JEST greatly reduces noise pollution both in and around e-JEST.





# POSITIVE PERFORMANCE

## BMW Battery Packs

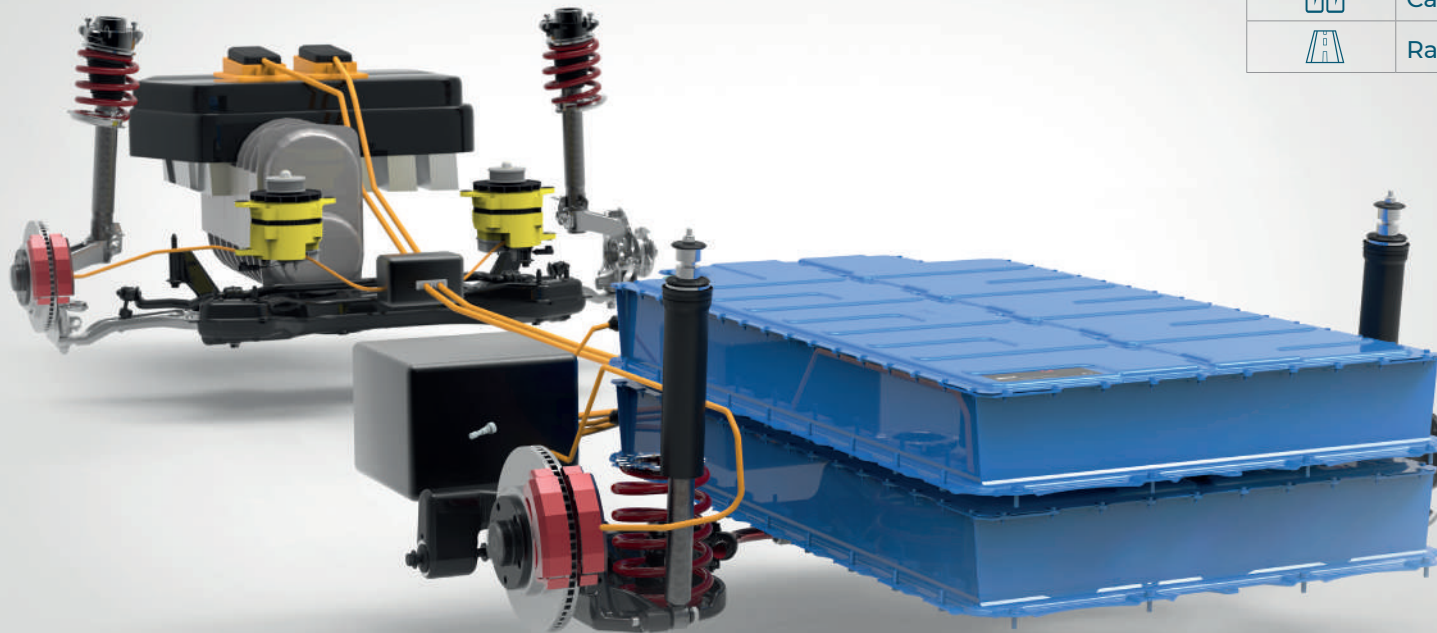

BMW Li-Ion batteries and electric motor bring e-JEST to life with its safe proven real world experience.



### Single Battery

	Capacity	44 kWh
	Range	105 km

### Double Battery

	Capacity	88 kWh
	Range	210 km

Battery warranty is limited to 4 years or 200.000 km (whichever finishes the first)

in cooperation with



## Quick and Easy Charging

e-JEST easily charges itself through the charging socket at the rear right side. e-JEST, which can be charged with two types of AC and DC, recharges battery for 2 hours\* at night and 55 minutes\* with quick charging during the day.

## Regenerative Power

During braking, e-JEST regenerates up to 25% of the kinetic energy and charges its batteries. This increases e-JEST's range.



\* For 44 kWh battery and up to 80% in ideal conditions. Charging socket location might be different on vehicles.





### **Comfortable Hill Start Even 25% Slope**

Steep hills do not pose a challenge for e-JEST. e-JEST is always ready with its strong motor to conquer any city terrain. It's efficient BMW motor generates high torque and reassures the driver in demanding situations. With its hill holder function, on steep hills it is as easy as going on the straight road.

### **Superior Maneuverability**

Thanks to the short turning radius and superior climbing performance, e-JEST travels easily in narrow streets of old cities and climbs up ramps while fully loaded.

# POSITIVE TECHNOLOGY

## 10" Full Digital Cluster

e-JEST is a good road companion. Because it shares everything and operates continuously to ease the driving. Its digital instrument cluster provides all vehicle information and warnings like charge status, remaining range and average consumption, for safe and easy operation. All you need to do is to enjoy a smooth ride.





### Keyless Start & Stop

Technological solutions which make life easier are incorporated into e-JEST. It is so smart that it does not need a key. RFID Card is enough for it to wake up. To start e-JEST, only touch the Start/Stop key after you insert the card. It's that simple to start e-JEST.



### 10.1" Multimedia Touchscreen

Everything is at the tip of your fingers thanks to the e-JEST's wide touchscreen, which is equipped with a radio/MP3 player, bluetooth and USB port for a more enjoyable journey. From this screen you can control air conditioning in the vehicle, select best routes with navigation, view rear camera and surveillance system for safe and easy driving experience.

### Wi-Fi and USB Ports

When you are in e-JEST, there is no distance between you and the world. You can always go online with e-JEST's Wi-Fi technology, and electronic devices can be charged through the USB ports in passenger area. e-JEST incorporates all the latest trends and high tech transportation needs for its passengers.

# POSITIVE SERVICE



# THE BEST CHOICE FOR MUNICIPAL AND PRIVATE CORPORATIONS



## Budget Friendly

Fossil fuel reserves are decreasing gradually. The decline triggers prices and reduces the profit margin of public transportation companies. This is where e-JEST comes in. Because e-JEST is electric powered, it does not pollute nature and reduces the total utility costs by using a more economical resource.

## Superior Durability

e-JEST is produced with technology gained from Karsan's 50+ years of manufacturing, including corrosion protection using cataphoresis techniques. In addition to being designed as a public transport vehicle, e-JEST will withstand years of daily use with its strong monocoque chassis and composite plastic and aluminum body panels. With these standard features, e-JEST will protect the user investment for the life of the vehicle.



## Maximum Capacity Utilization

e-JEST reduces operational costs during off peak hours where oversized empty buses has redundant capacity. Thus it offers the capacity as required by a city for these hours and brings an affordable approach to public transportation.



### Capacity Utilization

Peak Hours  
**%100**

Off-Peak Hours  
**%100**



5,8 mt e-JEST | 22 Passenger Capacity



8 mt Bus | 58 Passenger Capacity

Peak Hours  
**%100**

Off-Peak Hours  
**%43**



12 mt Bus | 105 Passenger Capacity

Peak Hours  
**%100**

Off-Peak Hours  
**%24**



# REMOVES THE CHALLENGES OF PUBLIC TRANSPORTATION



Ergonomic Cockpit



Digital Route Indicator



Semi Closed Driver Cabin



Sliding Passenger Door



Outward Swing Passenger Door



Validator Preparation



# OFFERS COMFORTABLE SERVICE TO CITIZENS

## Independent Suspension

Until e-JEST, passenger and operator comfort has not been expected in public transport. With 4-wheel independent suspension, e-JEST reduces road vibration and increases passenger comfort offering an automobile like comfort.

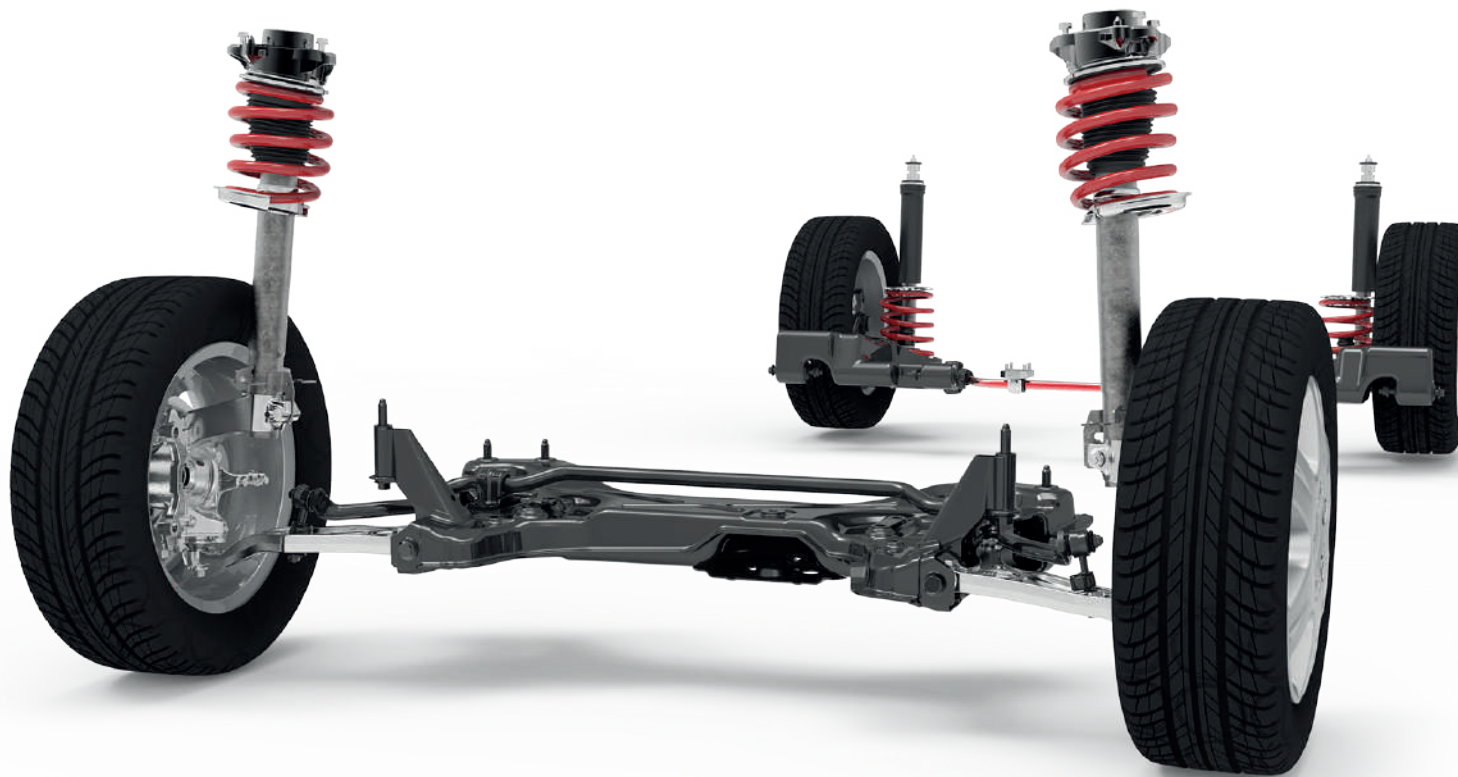

## Original Low Floor

Getting in e-JEST is as easy as walking on the straight road. The low floor allows passengers to get in by just a half step. Thanks to these advantages, the parents with stroller and the elderly get on and off e-JEST easily.











### **Spacious Interior**

In addition to adequate seat width and ample space between the seats, e-JEST offers spacious travel possibilities with its roomy interior design and panoramic windows, so the passengers just need to sit back and relax while viewing the cityscape.

### **Seat Positioning**

Passengers getting on the e-JEST can reach seats positioned on the low floor conveniently without an extra step. Moreover, with all the front-facing fixed seats, all passengers spend a pleasurable time in e-JEST.

## Passenger Capacity & Layout Alternatives

						
	Battery Capacity	Seated	Foldable	Wheelchair	Max. Standing**	Max. Total Passenger**
Class I	44 kWh	9	2	1	13	22
Class A		9	2	1	13	22
Class A	88 kWh	10	2	1	9	19
		9	2	1	10	19

\*Values are examples. These values may change as +/- depending on the selected features.



# POSITIVE SAFETY

e-JEST offers technological active and passive safety systems in order to protect its valuable driver and passengers.



ELECTRONIC STABILITY PROGRAM



ANTI-LOCK BRAKING SYSTEM



DRAG TORQUE CONTROL



HILL START AID



ELECTRONIC BRAKEFORCE DISTRIBUTION



TRACTION CONTROL SYSTEM



BRAKE ASSIST SYSTEM



## CHANGING HABITS REQUIRES POSITIVE ENERGY

The mini-bus emerged as part of economic priorities 60 years ago in the friendly lands of Anatolia. It began to spread to modern cities in the 1980's and continues to grow as more cities increase their sustainable transportation network.

e-JEST is designed to change the outlook of public transportation in many parts of the world, it is designed to challenge public transport perceptions.

Upgrading public transportation, e-JEST develops a collective travel model in developing modern cities reducing the need for passenger cars. e-JEST accomplishes this both with its comfort and unique features, as well as its respect for nature.

e-JEST provides solutions to transportation issues with new generation technology, and becomes the source of happiness for communities.



# KARSAN... FROM PAST TO PRESENT

1966



Karsan's adventure began in 1966 with 269 independent entrepreneurs.

1981

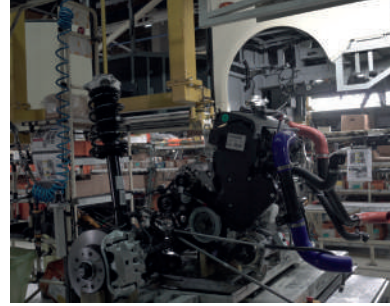

In the first 15 years, it continued to work as a part supplier for Original Equipment Manufacturers (OEMs).

2006



From 1981 onwards, it began manufacturing J9 minibuses for Automobiles Peugeot. Later, it manufactured the first minivan in collaboration with Peugeot.



In 2006, Karsan manufactured J9 Premier, which was completely its own product. In the following year, it established strategic alliances with Hyundai, Renault and Citroen.

2021



Karsan expands its 10-12-18 meter bus range for urban transportation needs.

2019



Karsan signed a 5-year contract with Oyak Renault for the production of Megane Sedan models.



Karsan introduced Autonomous e-ATAK, the first serial-production level 4 bus in Europe and America.



Karsan now manufactures e-ATAK for a sustainable future and preserve natural resources of historical cities.



**2009**



In line with its vision updated in 2009 as “Limitless Transportation Solutions”, Karsan developed the V1 project in response to New York’s Taxi of Tomorrow tender.

**2011**



Starting to manufacture buses in 2011, Karsan manufactured the first big bus for Rome Municipality.

**2013**



In 2013, it re-developed its product portfolio with its own vehicles, namely Jest, Atak and Star.

**2017**



Jest+ was relaunched with an esthetic look and enhanced features.

**2018**



Karsan’s first electric vehicle e-JEST, which is electrified by BMW i, was launched in Munich, in cooperation with BMW.



Karsan’s factory, located in Hasanağa, Bursa, Turkey, having 90.000 m2 of indoor space on a total area of 200.000 m2, has a capacity of manufacturing 65.000 vehicles/year. Today, in its modern facilities Karsan has been producing for more than 50 years for the world’s leading brands and its own brand.



Karsan became one of the 6 finalists in the prototype design contest for a next generation delivery vehicle at US Postal Service and remained in the evaluation stage for five years and the tender was awarded to another bidder in February 2021.

## TECHNICAL SPECIFICATIONS

### VEHICLE TYPE

Vehicle Category & Class	M2 Category & Class 1 / Class A
--------------------------	---------------------------------

### POWERTRAIN SYSTEM

Drive Type	Battery Electric Vehicle (BEV)
Engine Type	Electric Traction Motor
Maximum Power (kW & hp)	135 & 184
Maximum Torque (Nm)	290
Transmission	Single Speed Automatic Transmission

### PERFORMANCE & ELECTRICAL SYSTEM

Top Speed (km/h)	70	
Maximum Gradeability (%)	25	
Battery Alternatives	<b>Single Battery</b>	<b>Double Battery</b>
Range (km) <sup>1</sup>	105	210
High Voltage Battery (Type - Capacity)	Li-ion - 44 kWh	Li-ion - 88 kWh
Charging AC Type 2 (Power - Time)	22 kW - 2h <sup>2</sup>	22 kW - 4h <sup>2</sup>
Charging DC Combo 2 (Power - Time)	50 kW - 55 min <sup>2</sup>	80 kW - 65 min <sup>2</sup>

### BODY

Body Type	Monocoque Space Frame - Original Low Floor (270mm Step Height)
Corrosion Resistance	Cataphoresis Coating & Under Coating

### SUSPENSION

Suspension System	4WIS-Four Wheel Independent Suspension System
Front Axle	Independent, MacPherson, Coil Springs & Telescopic Shock Absorber
Rear Axle	Trailing Arm, Helical Spring + Anti Roll Bar

### BRAKES

Front & Rear Brakes	Hydraulic & Disc
---------------------	------------------

### DIMENSIONS

Overall Length (mm)	5.845
Overall Width (mm)	2.055 (without mirrors)
Overall Height (mm)	2.850 (with A/C)
Interior Height (mm)	2.185 (maximum)
Front Overhang (mm)	1.200
Rear Overhang (mm)	895
Wheelbase (mm)	3.750
Turning Radius (mm)	6.993

### TIRES

Tire Sizes	215 / 75 R 16C
Rim Sizes	6J x 16"

<sup>1</sup>Based on NEDC testing standards with a base-level equipped vehicle. Range may vary depending on various factors, in particular: individual driving style, route characteristics, outside temperature, heating/air conditioning, seated & standing passenger weight.

<sup>2</sup>Charging up to 80% battery capacity in ideal conditions.

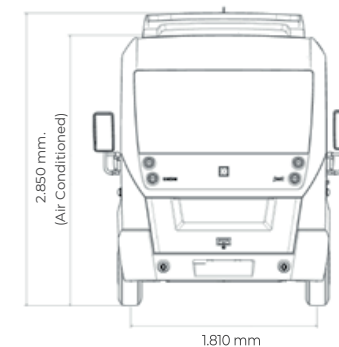
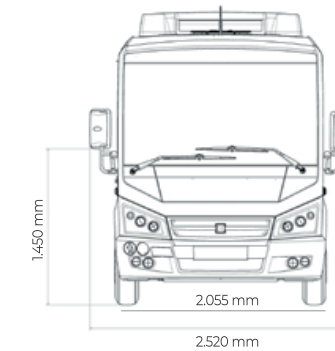
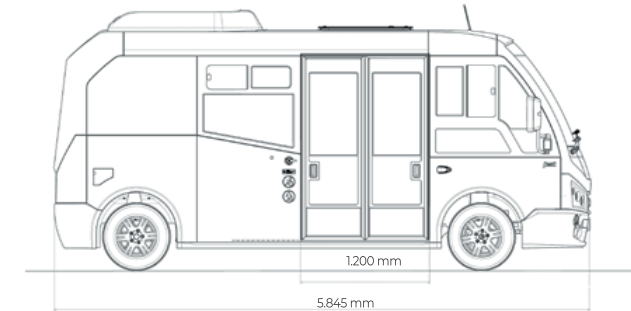
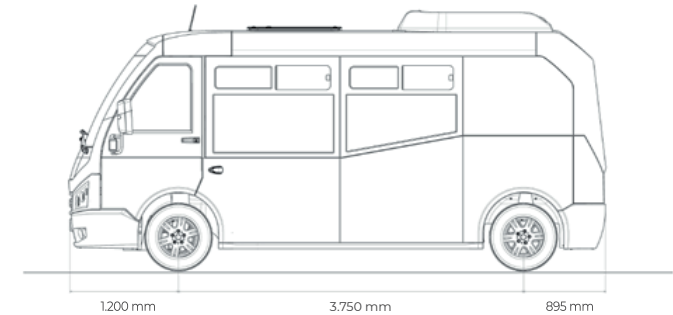

## EQUIPMENT FEATURES

### STYLE

Exterior Design	
LED High Beam & Low Beam Lights	S
LED DRL (Day Time Running Lights)	S
LED Fog Lamps	S
LED 3 <sup>rd</sup> Stop Lamp	O
Rear Clearance Lamps	O
16" Alloy Wheels	S
Tinted Side Glasses & Transom Windows	S
Driver Door	S
Outward Swing Passenger Door	S
Sliding Passenger Door <sup>3</sup>	O
Manual Access Ramp	S
Electric Access Ramp <sup>3</sup>	O
Body Colored Bumpers	S
Passenger Compartment	
Blue Handrails	S
Stainless Steel Handrails	O
2 Stop Buttons on Handrails	S
TECHNOLOGY	
Driver Compartment	
Leather Steering Wheel	S
10" Digital Cluster	S
Electric Park Brake	S
10,1" Multimedia Touchscreen	S
Speed Limiter - 50 km/h (On-off available)	S
2 Mode Regeneration Module	S
Acceleration Limiter (On-off available)	S
Rear Parking Sensor	O
Navigation	S
Camera Systems	
Rear View & Driver & Service Door Camera & DVR (1 TB)	O
Front & Inside & Rear View & Driver & Service Door Camera & DVR (1 TB)	O
Video & Audio Systems	
Radio + USB Port + Bluetooth Connections	S
4 Speakers	S
External Speaker	O
Goose Neck Microphone + Amplifier	O

Passenger Compartment	
Stop Sign & Digital Clock	S
USB On Handrails	S
6 x USB on Sidewall	O
Internet Access Infrastructure (Wi-Fi Router)	O
Line Systems	
Smart Tachograph	O
Heightened Roof Destination Info Preparation with Digital Route Indicator <sup>4</sup>	O
Validator Preparation	O
COMFORT	
Heating & Cooling System	
Roof Mounted Passenger A/C (12 kW)	S
Driver AC	S
High Voltage Heater (7 kW)	S
Pre-heater (Diesel) <sup>5</sup>	O
Mirrors & Windows	
Manual Roof Hatch	S
Electric Roof Hatch	O
Electric & Heated Side Mirrors	S
Sidewalk Mirror on Right	S
Electric & Heated Driver Window	S
Heated Front Right Window	S
Heated Windscreen	S
Front Manual Sun Visor (Driver Only)	S
Interior Lights	
Driver Area Illumination	S
Passenger Area LED Light Path	S
Driver Compartment	
Tiltable & Telescopic Hydraulic Steering Wheel	S
Remote Controlled Central Locking System	S
8 Way Adjustable Pneumatic Driver Seat With Arm Rest	S
Driver Overhead Bin	S
Semi-Closed Driver Cabin (with Hand Luggage Area)	S
Fully Separated Driver Cabin	O

Passenger Compartment	
Plastic Type Passenger Seats	S
Plastic Type Passenger Seats with Fabric	O
Billboard <sup>6</sup>	O
Other	
12V Battery	S
22 kW High Capacity Charger	S
CCS2 Charging Cable (3 Phases x 32A)	O
FMS Gateway	S
SAFETY	
ESP - Electronic Stability Program	S
Hill Holder	S
ABS - Anti-lock Braking System	S
EBD - Electronic Brake Force Distribution	S
HBA - Hydraulic Brake Assistant	S
VDC - Vehicle Dynamics Control	S
TCS - Traction Control System	S
DTC - Drag Torque Control	S
TPMS - Tire Pressure Monitoring System	S
Battery Room Fire Detection System	S
Electric Motor Fire Detection System	S
Fire Suppression System (For Pre-Heater) <sup>7</sup>	O
Brake Pad Wear Sensor	S
Reverse Gear Buzzer	S

<sup>3</sup> Can't be used with 88 kWh + Class A + 9 Fixed + 2 Foldable Layout.

<sup>4</sup> It can be provided also without indicator.

<sup>5</sup> With standard heating system.

<sup>6</sup> Only with Fully Separated Driver Cabin.

<sup>7</sup> If pre-heater option is selected in Class I vehicle, this option must be selected. If pre-heater is not selected in Class A vehicle, this option can not be selected.

S = Standard  
O = Option

Authorized Dealer



All information and images included in this brochure are based on the technical specifications that are applicable on the printing date of the brochure.  
All features provided are standard or optional depending on different versions of the vehicles. In the scope of continuous product improvement policy, Karsan always reserves its right to make changes in the specifications without providing any notification to third parties. This brochure does not constitute an offer to sell vehicles.